

Eseguire n° 4 fori Ø 8 mm.  
MAKE FOUR EXHAUST PORTS OF 8 MM. DIAM.

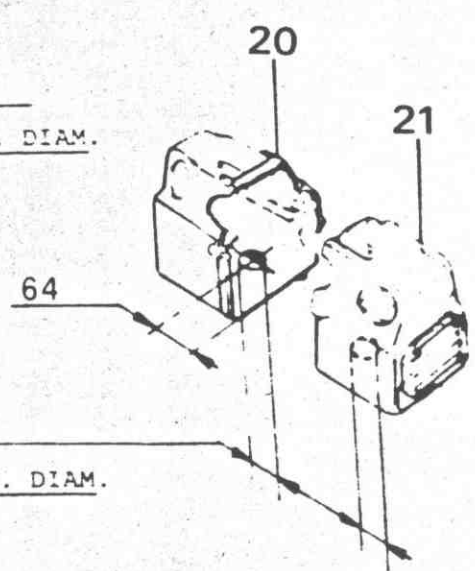

Eseguire n° 2 fori Ø 40 mm.  
MAKE TWO INTAKE HOLES OF 40 MM. DIAM.



POS.	PART. N.	QTY	DENOMINAZIONE	PARTS	PRICE
1	47 207 154	3	COPPIA PASTIGLIE FRENANTI	PAIR OF PADS	13.500-
2	47 202 151	2	PINZA FRENO DX SERIE ORO	RH CALIPER, GOLD LINE	67.500
3	47 201 149	3	DISCO FRENO FLOTTANTE	FLOATING DISC	340.000
4	47 509 190	1	RUOTA ANTERIORE NERA	FRONT WHEEL, BLACK	181.500
5	47 202 150	1	PINZA FRENO SX SERIE ORO	LH CALYPER, GOLD LINE	67.500
6	55 120 180	1	GRUPPO REVISIONE GUARNIZIONI	GASKETS OVERHAUL SET	8.280
7	61 602 085	1	CPOPERTURA POST. PIRELLI	130/80 V 18 REAR TYRE	98.120
8	47 509 188	1	RUOTA POSTERIORE NERA	REAR WHEEL, BLACK	183.700
9	73 201 012	3	CANDELA N2 CHAMPION	N2 CHAMPION SPARK PLUG	2.340
10	50 320 245	6	ANELLO FERMO SPINOTTO	CIRCLIP	220
11	34 120 258	3	SPINOTTO PISTONE ALLEGERITO	GUDGEON PIN	4.420
12	43 504 132	3	PISTONE STAMPATO	FORGED PISTON	55.000
12	43 504 133	-	PISTONE I MAGG.	PISTON, 1st REBORING	55.000
12	43 504 134	-	PISTONE II MAGG.	PISTON, 2nd REBORING	55.000
13	25 102 097	1	TESTA CON GUIDAVALVOLE	CYLINDER HEAD	417.410
14	52 501 014	3	VALVOLA DI SCARICO	EXHAUST VALVE	16.550
15	52 501 013	3	VALVOLA DI ASPIRAZIONE	INLET VALVE	22.000
16	61 202 047	1	SELLA BIPOSTO NERA	DUAL SET, BLACK	99.000
17	61 916 604	2	SCRITTA CORSA PER FIANCHETTI	BADGE "CORSA"	2.100
18	62 500 158	3	GETTO MAX 118	MAIN JET 118	1.180
19	63 503 193	2	MARMITTA	SILENCER	104.500
20	62 110 110	1	SCATOLA DX FILTRO ARIA	RH AIR FILTER BOX	13.200
21	62 110 108	1	SCATOLA SX FILTRO ARIA	LH AIR FILTER BOX	13.200