

Laverda 1000-3CL (working model)

Block Dia v16 (Detail)

changed: 6 to 5+4
 1 Neutral 150
 1 Neutral 151
 1 Indi LHS 722
 1 Indi RHS 712
 1 High Beam 412
 1 Dashboard 170
 +1 Rev Count 870
 +1 Rev Count 871 (to 15A)

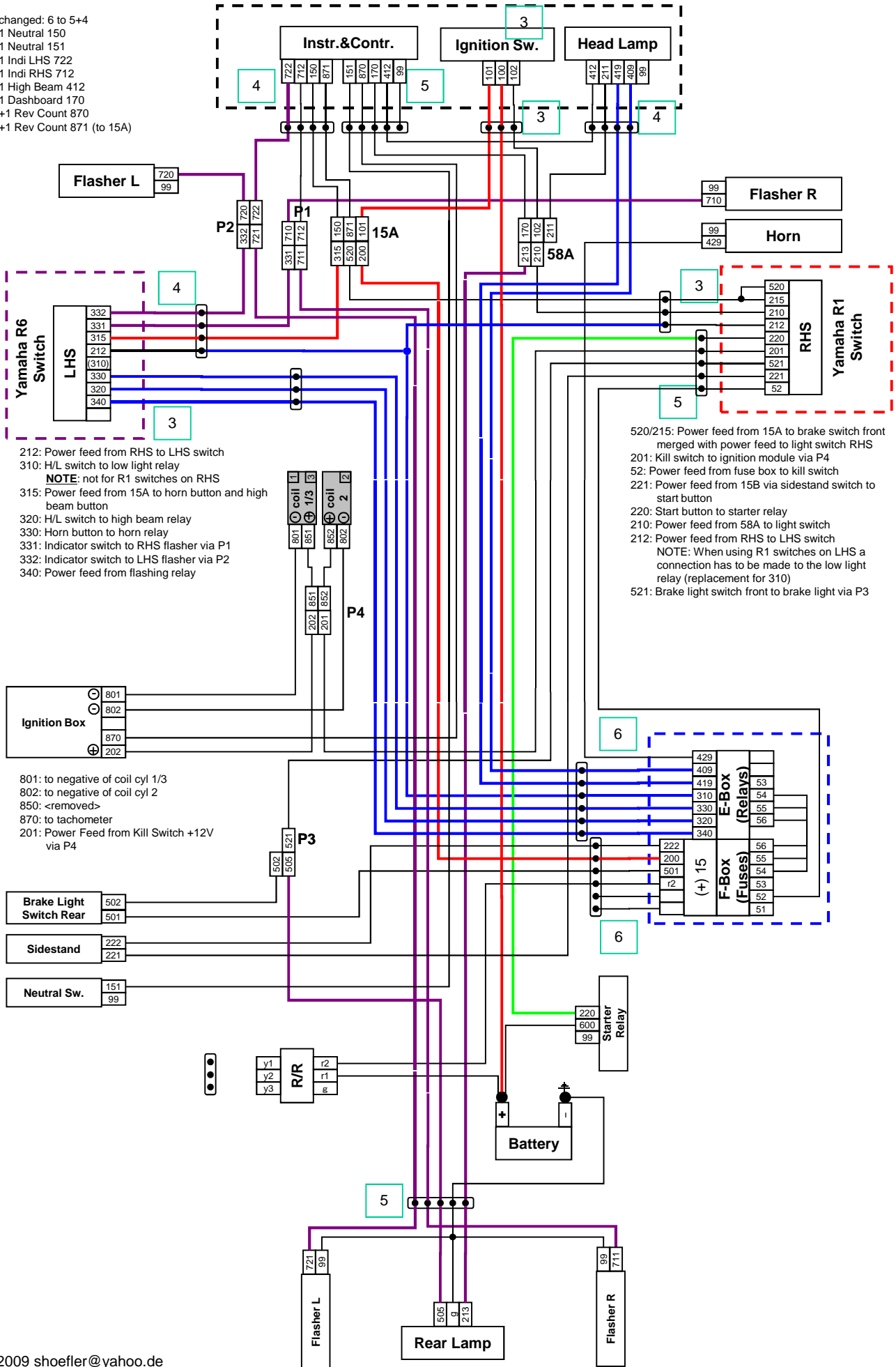

212: Power feed from RHS to LHS switch
 310: H/L switch to low light relay
NOTE: not for R1 switches on RHS
 315: Power feed from 15A to horn button and high beam button
 320: H/L switch to high beam relay
 330: Horn button to horn relay
 331: Indicator switch to RHS flasher via P1
 332: Indicator switch to LHS flasher via P2
 340: Power feed from flashing relay

801: to negative of coil cyl 1/3
 802: to negative of coil cyl 2
 850: <removed>
 870: to tachometer
 201: Power Feed from Kill Switch +12V via P4

520/215: Power feed from 15A to brake switch front merged with power feed to light switch RHS
 201: Kill switch to ignition module via P4
 52: Power feed from fuse box to kill switch
 221: Power feed from 15B via sidestand switch to start button
 220: Start button to starter relay
 210: Power feed from 58A to light switch
 212: Power feed from RHS to LHS switch
NOTE: When using R1 switches on LHS a connection has to be made to the low light relay (replacement for 310)
 521: Brake light switch front to brake light via P3